

Pass Laboratories
Aleph 5 Owner's Manual

Serial #

Dear Customer,

The Aleph 5 is the fourth of the newest generation of amplifiers from Pass Labs. This design results from my commitment to create the best sounding product, a simple circuit having the most natural characteristic. The Aleph 5 integrates power Mosfet devices and pure single ended Class A operation in a simple two-gain-stage topology with the sole purpose of recreating subjectively natural sound.

The Aleph 5 is unique in a number of ways:

Unlike the early Aleph amplifiers, it operates in pure single-ended mode over its entire operating region, and does not incorporate a "pull" stage for additional current beyond its bias point. When the single-ended output Mosfets (four sets of three in parallel) reach cutoff, the amplifier clips.

Most amplifiers on the market have between five and seven gain stages in series between the input and the output. The Aleph 5 has but two, and enjoys a very direct path from input to output, further enhancing the purity of the circuit and the resulting sound. Early Aleph amplifiers have three gain stages.

The output stage of the Aleph 5 is a unique blend of traditional design and innovation addressing the unique requirements of loudspeakers. Previous methods of loading the output stage have used networks consisting of resistors, coils, transformers, and active current sources, all of which offer an optimal load line based on a resistive load. The Aleph 5 has a current source topology which optimizes performance for a wide range of impedance and reactance in the load, improving all aspects of performance into real loudspeakers. Pass Labs has a US patent pending on this output stage topology.

The Aleph 5 is unique in that there are no adjustments of any kind in the circuitry. There are no potentiometers to adjust. The operating parameters of bias currents and DC offset and so on are defined by physical constants, and will not go out of adjustment.

Most important, the Aleph 5 brings a new dimension to the recreation of subjective sonic reality. The amplifier delivers detail and subjective space rarely found in semiconductor circuits, coupled with the authority and clarity rarely found in tube amplifiers.

Thank you for purchasing this amplifier. I have personally performed the tests on it, and guarantee that it meets our production standards. Accompanying are the distortion curves for this particular amplifier.

This amplifier is different. I have considerable confidence that you will like it, but as the performance is subjective, you be the judge.

Nelson Pass

Setup

The amplifier has three sets of connections and one switch: The first connection and switch is the AC line power system. The amplifier's voltage and current rating are indicated on the bottom. It will be either 240 volts, 120 volts, or 100 volts, all with a 3AG slow blow type fuse as indicated on the sticker. The frequency rating of the AC line source is 50 to 60 Hz.

Your amplifier is provided with a standard AC power cord which fits into the line receptacle located just below the power switch. The amplifier is equipped for operation with an earth ground provided by the AC outlet. Do not defeat this ground. The chassis of the amplifier is connected directly to this earth ground, and the audio circuit ground is connected to the chassis and earth through a power thermistor, which gives a ground safety connection but helps avoid ground loops. While the amplifier is equipped with an AC inrush suppresser, the turn-on AC draw will peak (half cycle) at roughly 50 amps on a 120 volt system.

The second set of connections is at the input, which occurs through a balanced XLR or standard RCA unbalanced connector for each channel. The input impedance of the amplifier is 10 K ohms unbalanced, and 25 Kohms balanced differential. The top set is the left channel, the bottom set is the right.

The third set of connections is the amplifier output connections. Connect the 5-way output connectors to loudspeaker plus and ground, using the cable of your choice. Use some care to insure that the hot output connection does not short to the chassis or other connectors. The top connector is the left channel, and the bottom is the right.

The amplifier draws 300 watts from the wall at all times, and during idle operation nearly all of this energy will appear as heat on the heat sinks. Good ventilation is vital to the proper operation of the amplifier. It has been adjusted for optimal performance at room temperature, but will work well between 50 and 90 degrees Fahrenheit (10 to 33 Celsius). You should leave at least six inches clearance on the sides and top. The amplifier should not be placed in a closed cabinet which does not have forced air ventilation.

This amplifier runs hot. The heat sinks will warm up in about an hour to a temperature which will not be comfortable to touch for more than a moment or two, which is 120 to 130 degrees Fahrenheit (50 to 55 degrees Celsius). This is normal, and there is a thermal shut off system which will shut down the amplifier at internal temperatures in excess of 160 deg. F. and 70 deg. C.

It takes at least an hour of warm up time to get the best performance out of the amplifier. It will take that long to reach operating temperature and exhibit lowest distortion and noise. This is not a subjective judgement, but based on actual distortion and noise measurements. You may find somewhat greater residual noise coming through the loudspeaker when the amplifier is first turned on, but it will decrease as the amplifier warms up.

The amplifier does not require any maintenance. While the design is conservative, this is a hard running amplifier, as single ended Class A operation is the least efficient operating mode. In fifteen years the electrolytic power supply capacitors will get old. Depending on usage, you will begin to have semiconductor and other failures between 10 and 50 years after date of manufacture. Later, the sun will cool to a white dwarf, and after that the universe will experience *heat death*.

Product Philosophy and Design Theory

When I started designing amplifiers 25 years ago, solid state amplifiers had just achieved a firm grasp on the market. Power and harmonic distortion numbers were king, and the largest audio magazine said that amplifiers with the same specs sounded the same.

We have heard Triodes, Pentodes, Bipolar, VFET, Mosfet, TFET valves, IGBT, Hybrids, THD distortion, IM distortion, TIM distortion, phase distortion, quantization, feedback, nested feedback, no feedback, feed forward, Stasis, harmonic time alignment, high slew, Class AB, Class A, Pure Class A, Class AA, Class A/AB, Class D, Class H, Constant bias, dynamic bias, optical bias, Real Life Bias, Sustained Plateau Bias, big supplies, smart supplies, regulated supplies, separate supplies, switching supplies, dynamic headroom, high current, balanced inputs and balanced outputs.

Apart from digitally recorded source material, things have not changed very much in twenty five years. Solid state amplifiers still dominate the market, the largest audio magazine still doesn't hear the difference, and many audiophiles are still hanging on to their tubes. Leaving aside the examples of marketing hype, we have a large number of attempts to improve the sound of amplifiers, each attempting to address a hypothesized flaw in the performance. Audiophiles have voted on the various designs with their pocketbooks, and products go down in history as classics or are forgotten. The used market speaks eloquently: Marantz 9's command a high price, while Dyna 120's are largely unwanted.

There has been a failure in the attempt to use specifications to characterize the subtleties of sonic performance. Amplifiers with similar measurements are not equal, and products with higher power, wider bandwidth, and lower distortion do not necessarily sound better. Historically, that amplifier offering the most power, or the lowest IM distortion, or the lowest THD, or the highest slew rate, or the lowest noise, has not become a classic or even been more than a modest success.

For a long time there has been faith in the technical community that eventually some objective analysis would reconcile critical listener's subjective experience with laboratory measurement. Perhaps this will occur, but in the meantime, audiophiles largely reject bench specifications as an indicator of audio quality. This is appropriate. Appreciation of audio is a completely subjective human experience. We should no more let numbers define audio quality than we would let chemical analysis be the arbiter of fine wines. Measurements can provide a measure of insight, but are no substitute for human judgment.

As in art, classic audio components are the results of individual efforts and reflect a coherent underlying philosophy. They make a subjective and an objective statement of quality which is meant to be appreciated. It is essential that the circuitry of an audio component reflects a philosophy which address the subjective nature of its performance first and foremost.

Lacking an ability to completely characterize performance in an objective manner, we should take a step back from the resulting waveform and take into account the process by which it has been achieved. The history of what has been done to the music is important and must be considered a part of the result. Everything that has been done to the signal is embedded in it, however subtly.

Experience correlating what sounds good to knowledge of component design yields some general guidelines as to what will sound good and what will not:

- 1) Simplicity and a minimum number of components is a key element, and is well reflected in the quality of tube designs. The fewer pieces in series with the signal path, the better. This is often true even if adding just one more gain stage will improve the measured specs.
- 2) The characteristic of gain devices and their specific use is important. Individual variations in performance between like devices is important, as are differences in topological usage. All signal bearing devices contribute to the degradation, but there are some different characteristics worth attention. Low order nonlinearities are largely additive in quality, bringing false warmth and coloration, while abrupt high order nonlinearities are subtractive, adding harshness while losing information.
- 3) Maximum intrinsic linearity is desired. This is the performance of the gain stages before feedback is applied. Experience suggests that feedback is a subtractive process; it removes information from the signal. In many older designs, poor intrinsic linearity has been corrected out by large application of feedback, resulting in loss of warmth, space, and detail.

High idle current, or bias, is very desirable as a means of maximizing linearity, and gives an effect which is not only easily measured, but easily demonstrated: Take a Class A or other high bias amplifier and compare the sound with full bias and with bias reduced. (Bias adjustment is easily accomplished, as virtually every amplifier has a bias adjustment pot, but it should be done very carefully). As an experiment it has the virtue of only changing the bias and the expectations of the experimenter.

As the bias is reduced the perception of stage depth and ambiance will generally decrease. This perception of depth is influenced by the raw quantity of bias current. If you continue to increase the bias current far beyond the operating point, it appears that improvements are made with bias currents which are much greater than the signal level. Typically the levels involved in most critical listening are only a few watts, but an amplifier biased for ten times that amount will generally sound better than one biased for the few watts.

For this reason, designs which operate in what has been referred to as "pure" Class A are preferred because their bias currents are much larger than the signal most of the time. As mentioned, preamp gain stages and the front ends of power amplifiers are routinely single ended "pure" Class A, and because the signal levels are at small fractions of a watt, the efficiency of the circuit is not important.

- 4) Given the assumption that every process that we perform on the signal will be heard, the finest amplifiers must employ those processes which are most natural. There is one element in the chain which we cannot alter or improve upon, and that is the air. Air defines sound, and serves as a natural benchmark.

Virtually all the amplifiers on the market are based on a push-pull symmetry model. The push-pull symmetry topology has no particular basis in nature. Is it valid to use air's characteristic as a model for designing an amplifier? If you accept that all processing leaves its signature on the music, the answer is yes.

One of the most interesting characteristics of air is its single ended nature. Sound traveling through air is the result of the gas equation

$$PV^{1.4} = 1.26 \times 10^4$$

where P is pressure and V is volume, and whose curve is illustrated in fig. 1. The small nonlinearity which is the result of air's characteristic is not generally judged to be significant at normal sound levels, and is comparable to the distortion numbers of fine amplifiers. This distortion generally only becomes a concern in the throats of horns, where the intense pressure levels are many times those at the mouth, and where the harmonic component can reach several per cent.

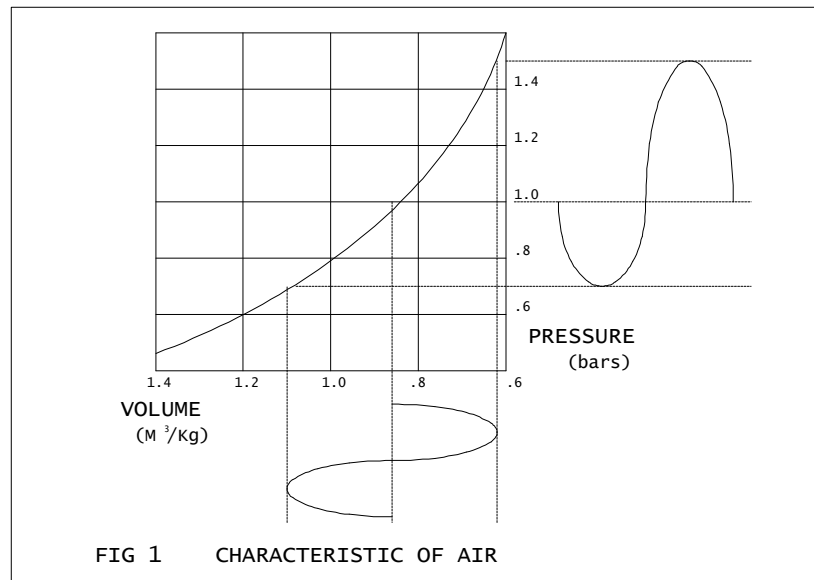

Fig. 1 shows the single ended nature of air. We can push on it and raise the pressure an arbitrary amount, but we cannot pull on it. We can only let it relax and fill a space as it will; the pressure will never go below "0". As we push on air, the increase in pressure is greater than the corresponding decrease when we allow air to expand. This means that for a given motion of a diaphragm acting on air, the positive pressure perturbations will be slightly greater than the negative. From this we see that air is phase sensitive.

As a result of its single ended nature, the harmonic content of air is primarily 2nd order, that is to say most of the distortion of a single tone is second harmonic. The phase of this distortion reflects the higher positive pressure over the negative.

Air's transfer curve also shows also that it is monotonic, which is to say its distortion products decrease smoothly as the acoustic level decreases. This is an important element that has often been overlooked in audio design and is reflected in the poor quality of early solid state amplifiers and D/A and A/D converters. They are not monotonic: the distortion increases as the level decreases.

The usual electrical picture of an audio signal is as an AC waveform, without a DC component. Audio is represented as alternating voltage and current, where positive voltage and current alternates with negative in a reciprocal and symmetric fashion. This fiction is

convenient because it lends itself to the use of an energy efficient design for amplifier power stages known as push-pull, where a "plus" side of an amplifier alternates operation with a "minus" side. Each side of a push-pull amplifier handles the audio signal alternately; the "plus" side supplying positive voltage and current to the loudspeaker, and the "minus" side supplying negative voltage and current.

Problems with push-pull amplifier designs associated with crossover distortion have been discussed elsewhere at length, and one of the primary results is non-monotonicity. Class B and many AB designs have distortion products that dramatically increase with decreasing signal. This is reduced greatly by Class A mode, but crossover distortion remains as a lower order discontinuity in the transfer curve.

For reproducing music as naturally as possible, push-pull symmetric operation is not the best approach. Air is not symmetric and does not have a push-pull characteristic. Sound in air is a perturbation around a positive pressure point. There is only positive pressure, more positive pressure, and less positive pressure.

Push-pull circuits give rise to odd ordered harmonics, where the phase alignment reflects compression at both positive and negative peaks and crossover nonlinearity near the zero point.

Push-pull operation in amplifiers is commonly portrayed by the analogy of a two-man saw cutting down a tree. Certainly if we are cutting down trees by hand, we would opt for this method, as it would be much more efficient.

As we are not cutting down trees, I much prefer the image of a violinist holding the bow at one end with one hand. Only in this manner does the musician gain the degree of control and precision required to produce the range and subtlety required by music. And so it is with single-ended amplifiers.

Only one linear circuit topology delivers the appropriate characteristic, and that is the single ended amplifier. Single ended amplification only comes in pure Class A, and is the least efficient form of power stage you can reasonably create, typically idling at three to five times the rated output power.

Single ended operation is not new. It is routinely found in the low level circuitry of the finest preamplifying stages and in the front end circuits of the finest power amplifiers. The first tube power amplifiers were single ended circuits using a single tube driving the primary of a transformer.

In 1977 I designed and published in Audio Magazine a single ended Class A amplifier using bipolar followers biased by a constant current source. A considerable number of amateurs have built the device, rated at 20 watts output, and many have commented on its unique sonic signature.

Single ended Class A operation is generally less efficient than push-pull Class A. Single ended Class A amplifiers tend to be even bigger and more expensive than their push-pull cousins, but they have a more natural transfer curve.

The "purity" of Class A designs has been at issue in the last few years, with "pure" Class A loosely defined as an idling heat dissipation of more than twice the maximum amplifier output. For a 100 watt amplifier, this would be 200 watts out of the wall at idle.

As the Aleph 5 idles at two and a half times its rated output, I think we can safely think of it as "pure".

Designs that vary the bias against the musical signal will generally have bias currents at or below the signal level. This is certainly an improvement from the viewpoint of energy efficiency, but the sound reflects the lesser bias point.

I authored the first patent on the dynamically biased Class A amplifier in 1974, however I have not used the technique for the last 15 years. The reason is that I found the quality of sound associated with an efficient Class A operating mode inferior in depth and less liquid at high frequencies, simply because it operates at reduced bias at low levels. Given the plethora of cool running "Class A" amplifiers on the market, you might say I opened a Pandora's box.

A very important consideration in attempting to create an amplifier with a natural characteristic is the selection of the gain devices. A single ended Class A topology is appropriate, and we want a characteristic where the positive amplitude is very, very slightly greater than the negative. For a current gain device, that would mean gain that smoothly increases with current, and for a tube or field effect device a transconductance that smoothly increases with current.

Triodes and Mosfets share a useful characteristic: their transconductance tends to increase with current. Bipolar power devices have a slight gain increase until they hit about an amp or so, and then they decline at higher currents. In general the use of bipolar in a single ended Class A circuit is a poor fit.

Another performance advantage shared by Tubes and Fets is the high performance they deliver in simple Class A circuits. Bipolar designs on the market have between five and seven gain stages associated with the signal path, but with tubes and Mosfets good objective specifications are achievable with only 2 or 3 gain devices in the signal path.

Readers of The Audio Amateur Magazine will be familiar with my "Zen" design, which uses a Mosfet in a power amplifier which has only one gain stage, and only one gain transistor. Research continues at Pass Labs in improving the performance of very simple gain circuits.

Yet a third advantage tubes and Mosfets have over bipolar devices is their greater reliability at higher temperatures. As noted, single ended power amplifiers dissipate comparatively high wattages and run hot. Bipolar devices are much more prone to failure at high temperatures.

In a decision between Triodes and Mosfets, the Mosfet's advantage is in naturally operating at the voltages and currents we want to deliver to a loudspeaker. Efforts to create a direct coupled single ended triode power amplifier have been severely limited by the high voltages and low plate currents that are the province of tubes. The commercial offerings have not exceeded 8 watts or so, in spite of hundreds of dissipated watts.

Transformer coupled single ended triode amplifiers are the alternative, using very large gapped-core transformers to avoid core saturation from the high DC current, but they suffer the characteristic of such a loosely coupled transformer as well.

The promise of the transconductance characteristic in power amplifiers in providing the most realistic amplified representation of music is best fulfilled in Mosfet single ended Class A circuitry where it can be used very simply and biased very high.

The Aleph 5 uses Mosfets exclusively for all gain stages. These Mosfets were chosen because they have the most ideal transfer curve for an asymmetric Class A design. Made in the United States, they have the highest quality of power Mosfets we have tested to date. We match the input devices to each other to within 0.2% and the output devices to within 2%. The smallest of these, the input devices, are capable of peak currents of 5 amps. The largest are capable of peaks of 50 amps each, and are run in parallel groups of three.

The power Mosfets in the Aleph 5 have chip temperatures ratings to 150 degrees Centigrade, and we operate them at small fractions, typically 20% of their ratings. For extended life, we do not allow chip temperatures to exceed 85 degrees C.

Regardless of the type of gain device, in systems where the utmost in natural reproduction is the goal, simple single ended Class A circuits are the topologies of choice.

It is a very simple topology, which is a key part of the sound quality. Other solid state amplifier designs have five to seven gain stages in the signal path in order to get enough gain to use feedback to provide adequate performance. In this amplifier, we get greater linearity by providing much more bias through two gain stages: a differential input stage, and the output transistors.

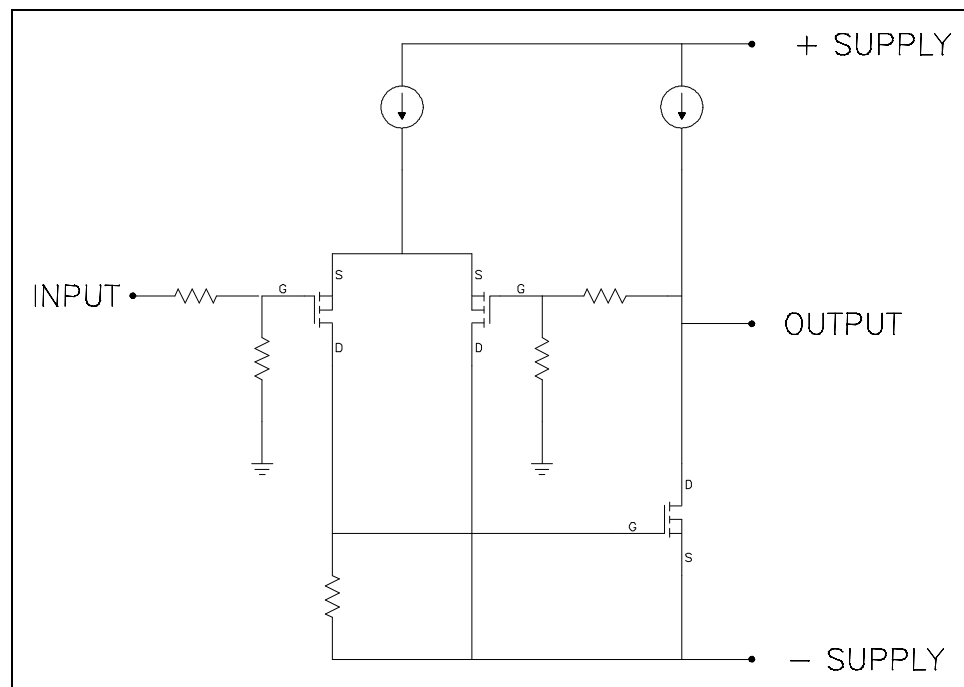

Mosfets provide the widest bandwidth of solid state power devices, however they were not chosen for this reason. The design of the Aleph 5 does not seek to maximize the amplifier bandwidth as such. The capacitances of the Mosfets provide a natural rolloff in conjunction

with the resistive impedances found in the circuit, and the simplicity of the circuit allows for what is largely a single pole rolloff characteristic.

For the lowest possible operating noise in any environment, the amplifier is equipped with balanced inputs featuring a common mode noise rejection of greater than 60 dB. Balanced operation is accomplished through a passive network tied directly into the input stage of the amplifier, not with additional active input circuitry as in other products. This assures that the noise benefits of balanced operation are not accompanied by the degradation of more semiconductors in the gain path.

The input of the amplifier is flexible and can also be operated with unbalanced sources. The input system will exhibit full common mode noise rejection with passive balanced sources, where the negative input is connected to ground at the source through the appropriate source impedance. This allows adaptation of unbalanced sources to balanced operation with passive cable connections in a manner that achieves the noise rejection of active balanced sources. Pin 1 of the XLR input connector is ground, pin 2 is the positive input, and pin 3 is the negative input.

The Aleph 5 is shipped with a shorting plug between pins 1 and 3 of the input XLR connectors. This shorting plug sets the gain of the amplifier to 26 dB when you are using the RCA unbalanced input. Removal of this plug will set the gain to 20 dB. Needless to say, you will remove this plug when using the balanced input. There is no penalty for not using this plug with unbalanced operation, and if you have particularly efficient loudspeakers, you may find that you prefer it this way.

The slew rate of the amplifier is about 30 Volts/uS under load , which is about 30 times faster than the fastest signal you will ever see, and about 100 times faster than what you will be listening to. In and of itself, the slew rate is an unimportant factor when evaluating tube and simple Mosfet designs. It becomes more important with complex circuit topologies where there is heavy dependence on feedback correction, but even then its importance has been overstated.

The amplifier is powered by a toroidal transformer which charges .12 Farad capacitance. This unregulated supply feeds the output transistors only with a full power ripple of about .5 volt. The power draw of this system is constant regardless of the music playing through the amplifier. As such, it does not depend on a high quality AC outlet or special power cords, since the dynamic performance does not create a variation in AC line draw. If the AC line is running low, the output stage will bias to a higher current level by way of compensation.

The amplifier is stable into any load impedance or reactance including a direct short, and will deliver clean audio signal into 4 ohms at 180 watt peaks.

The Aleph 5 is impervious to electrostatic shock at the input and dead shorts at the output. You can safely plug and unplug inputs and outputs while the amplifier is running. (Do not try this with other products).The Aleph 5 is protected from overheating by a 75 degree C. thermostatic switch, and from internal failure by a slow-blow fuse.

The Aleph 5 is warranted by Pass Laboratories to meet performance specifications for 3 years from date of manufacture. During that time, Pass Laboratories will provide free labor and parts at the manufacturing site. The warranty does not include damage due to misuse or abuse or modified products and also does not include consequential damage.

SPECIFICATIONS

Gain	20 dB balanced, 20 or 26 dB balanced
Freq. Response	- 0.5 dB at 2 Hz, -2 dB at 100 KHz
Power Output	60 watts/ch 8 ohms 90 watts/ch 4 ohms
Maximum Output	30 volts, 8 amps
Distortion (1KHz)	1 % @ 60 watts, 8 ohms 3% @ 90 watts, 4 ohms
Input Impedance	10 Kohm unbalanced 25 Kohm balanced differential
Damping factor	50 nominal
Output Noise	600 uV unweighted
DC offset	< 100 mv
Power Consumption	300 watts
Temperature	25 degrees C. above ambient
Dimensions	12 " W x 12" D x 10.5" H
Shipping Weight	60 lb.



Pass Laboratories
PO Box 219
24449 Foresthill Road
Foresthill CA 95631

tel (530) 367 3690

fax (530) 367 2193